

# General Information

**Cavity Number**  
Tells which cavity used during multi-cavity production.

**Size**  
Shank diameter in inches.



**Lifting Eye Traceability Markings**

**Forging Code**  
Identifies equipment used during forging operation.

**Heat Code**  
Refers to specific heat of steel used.

**Diamond "D" Logo**  
Manufacturing trademark of the Edward W. Daniel Company

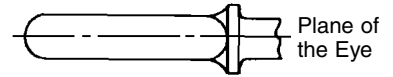

**Application:**

(a) Loads should always be applied to lifting eyes in the plane of the eye, not at some angle to this plane.

(b) Shoulder lifting eyes must be properly seated (should bear firmly against the mating part) otherwise the working loads must be reduced substantially. A steel washer or spacer may be required for proper seating.

(c) No greater load should be allowed than that given under rated capacity in each of the tables of dimensional data.

(d) To obtain greatest strength from a lifting eye, it must fit reasonably tight in the hole into which it is screwed to prevent unscrewing due to twist of cable. Tightness and seating must be checked after initial load.

(e) Lifting eyes should never be painted or otherwise coated when used for lifting, as such coatings will very likely cover up flaws.

(f) To attain the rated capacity listed for regular lifting eyes, full thread engagement allowing 1/2 turn for alignment to the plane of the eye is necessary.

**Physical Testing:**

Each lot of standard lifting eyes is manufactured and tested according to ASTM A489-93 and ANSI B18. 15.

**BREAKING STRENGTH:** The threaded shank is screwed into one jaw of a testing machine and a pin secured to the other jaw passed through the eye.

**BEND TEST:** Unthreaded parts must be capable of being bent to pressure or blows through 45° without showing cracks or indications of failure.

**TENSILE TEST:** Per ASTM A489.

**PLAIN & SHOULDER LIFTING EYES**

**Material Data:**

Grade ..... C1030  
Heat Treat ..... Quench & Draw

**Mechanical Properties:**

Grain Size ..... 5 or Finer  
Tensile ..... 65,000 psi min.  
Yield ..... 30,000 psi min.  
Elongation ..... 30% min.  
Reduction of Area ..... 60% min.

Diamond "D" Lifting Eyes are processed and tested to the above requirements. Tests are performed on randomly selected lifting eyes from a given heat lot.

**LIMITED WARRANTY:** See page 36 .

**CERTIFICATIONS:** Request for certification(s) must be made at time of order entry and there will be a charge associated with the certification.

**FORGING TOLERANCES:** Tolerances on all forged products is 1/32".

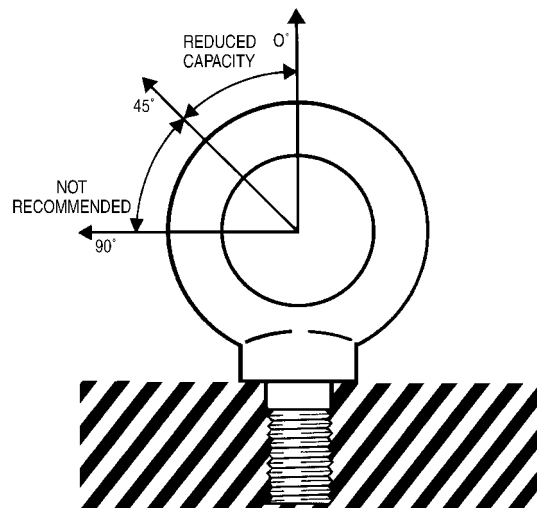

## Lifting Eye Capacities

DIAMETER	RATED CAPACITY					
	0°		45°		over 45°	
IN.	MM	LBS.	KGS	LBS.	KGS	
1/4	(M6)	500	(210)	125	(52)	N
5/16	(M7)	900	(370)	225	(92)	O
3/8	(M8)	1,300	(500)	325	(125)	T
7/16	(M10)	1,800	(740)	450	(185)	
1/2	(M12)	2,400	(1,030)	600	(257)	
9/16	(M14)	3,200	(1,600)	800	(400)	R
5/8	(M16)	4,000	(1,810)	1,000	(452)	E
3/4	(M18)	5,000	(2,140)	1,250	(535)	C
7/8	(M20)	7,000	(2,860)	1,750	(715)	O
1	(M24)	9,000	(3,850)	2,250	(962)	M
1-1/8	(M27)	12,000	(5,200)	3,000	(1,300)	M
1-1/4	(M30)	15,000	(6,400)	3,750	(1,600)	E
1-1/2	(M36)	21,000	(8,970)	5,250	(2,242)	N
1-3/4	(M45)	28,000	(11,960)	7,000	(2,990)	D
2	(M52)	38,000	(16,230)	9,500	(4,057)	E
2-1/2	(M65)	56,000	(24,200)	14,000	(6,000)	D

(Metric in Parenthesis)

**NOTE ON LIFTING EYE & NUT EYE BOLT RATED CAPACITIES**  
All rated lifting capacities included in the product charts are based on full sized shank and eye unaltered, and unaltered threading.

### Lifting Eye Capacities & Safety information

**Rated Capacity:** The maximum recommended load that should be exerted on the item at zero degree vertical pull. All rated load values are for pulls exerted in the plane of the eye.

**Ultimate Strength:** As defined in the machinist's handbook is: the stress at which a material in tension, compression, or shear will rupture or fracture.

**Yield Strength:** The maximum stress that can be applied to a material without permanent deformation of the material.

**Safety Factor:** An industry term denoting theoretical capability. Lifting eye rated capacity is figured with a 5 to 1 safety factor for a zero degree straight vertical pull

**Dimensions in Inches · Weight in Pounds**  
**Please include stock number and size when ordering**



# Eye Bolts

## Machinery Style Plain Pattern

- Forged/ASTM A489
- 1030 Carbon Steel
- Self-Colored\*\*

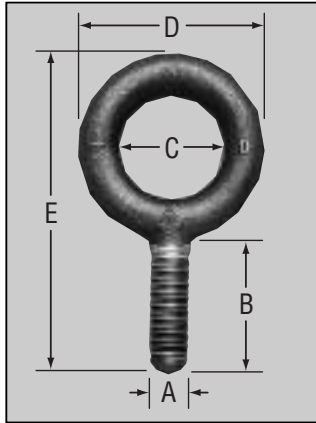

Stock No.	Zink Plated Stock No.	Thread Size UNC-2A A	Shank Length B	I.D. Eye C	O.D. Eye D	Overall Length E	Approx. Wt. Per 100 Pcs.	Rated Capacity	Blanks*
13611	ZP13611	1/4-20	1	3/4	1 1/16	2 7/32	5.0	500	R13611
13621	ZP13621	5/16-18	1 1/8	7/8	1 7/16	2 19/32	10.0	900	R13621
13631	ZP13631	3/8-16	1 1/4	1	1 11/16	3	15.0	1,300	R13631
13638	ZP13638	7/16-14	1 3/8	1 3/32	1 13/16	3 7/32	20.0	1,800	R13638
13641	ZP13641	1/2-13	1 1/2	1 3/16	2 1/8	3 21/32	35.0	2,400	R13641
13650	ZP13650	9/16-12	1 3/4	1 3/8	2 9/16	4 3/8	60.0	3,200	R13650
13661	ZP13661	5/8-11	1 3/4	1 3/8	2 9/16	4 3/8	60.0	4,000	R13661
13672	ZP13672	3/4-10	2	1 1/2	2 13/16	4 7/8	90.0	5,000	R13672
13682	ZP13682	7/8-9	2 1/4	1 11/16	3 3/16	5 1/2	145.0	7,000	R13682
13702	ZP13702	1-8	2 1/2	1 13/16	3 9/16	6 1/8	200.0	9,000	R13702
13712	ZP13712	1-1/8-7	2 3/4	2	4 1/16	6 7/8	285.0	12,000	R13712
13723	ZP13723	1-1/4-7	3	2 3/16	4 7/16	7 1/2	390.0	15,000	R13723
13753	ZP13753	1-1/2-6	3 1/2	2 1/2	5 3/16	8 3/4	635.0	21,000	R13753
13770	ZP13770	1-3/4-5	3 3/4	2 7/8	6	9 13/16	1050.0	28,000	R13770
13780	ZP13780	2-4 1/2	4	3 1/4	6 7/8	11	1470.0	38,000	R13780
13790	ZP13790	2-1/2-4	5	4	8 1/2	13 5/8	2900.0	56,000	—

Part #13650 dimensions not in accordance with ANSI B18.15.

## 8 Thread Pitch Machinery Style Plain Pattern

- Forged/ASTM A489
- 1030 Carbon Steel
- Self-Colored\*\*

Stock No.	Thread Size UNC-2A A	Shank Length B	I.D. Eye C	O.D. Eye D	Overall Length E	Approx. Wt. Per 100 Pcs.	Rated Capacity
813712	1-1/8-8	2 3/4	2	4 1/16	6 7/8	285.0	12,000
813723	1-1/4-8	3	2 3/16	4 7/16	7 1/2	390.0	15,000
813753	1-1/2-8	3 1/2	2 1/2	5 3/16	8 3/4	635.0	21,000
813770	1-3/4-8	3 3/4	2 7/8	6	9 13/16	1050.0	28,000
813780	2-8	4	3 1/4	6 7/8	11	1470.0	38,000
813790	2-1/2-8	5	4	8 1/2	13 5/8	2900.0	56,000

\*Blanks have no rated capacity.

## High Strength Eye Bolts

- Forged • 8620 Alloy Steel
- Low Temperature Application

Stock No.	Thread Size UNC-2A A	Shank Length B	I.D. Eye C	O.D. Eye D	Overall Length E	Approx. Wt. Per 100 Pcs.	Rated Capacity
13631LT	3/8	1 1/4	1	1 11/16	3	16.0	1,480
13641LT	1/2	1 1/2	1 3/16	2 1/16	3 21/32	34.8	2,700
13661LT	5/8	1 3/4	1 3/8	2 9/16	4 3/8	67.0	4,300
13672LT	3/4	2	1 1/2	2 13/16	4 7/8	100.0	6,400
13682LT	7/8	2 1/4	1 11/16	3 3/16	5 1/2	163.0	8,800
13702LT	1	2 1/2	1 13/16	3 9/16	6 1/8	222.0	11,600

## Machinery Style Stainless Steel

- 304 Stainless Steel

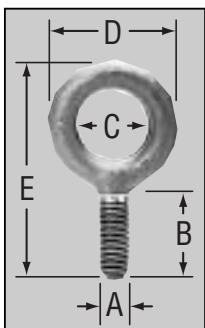

Plain Pattern

Stock No.	Thread Size UNC-2A A	Shank Length B	I.D. Eye C	O.D. Eye D	Overall Length E	Approx. Wt. Per 100 Pcs.	Rated Capacity	Blanks*
SS13611	1/4-20	1	3/4	1 1/16	2 3/8	5.0	460	SSR13611
SS13621	5/16-18	1 1/8	7/8	1 7/16	2 19/32	9.6	780	SSR13621
SS13631	3/8-16	1 1/4	1	1 11/16	3	14.0	1,160	SSR13631
SS13641	1/2-13	1 1/2	1 3/16	2 1/8	3 21/32	29.5	2,150	SSR13641
SS13661	5/8-11	1 3/4	1 3/8	2 9/16	4 3/8	58.0	3,440	SSR13661
SS13672	3/4-10	2	1 1/2	2 13/16	4 7/8	88.5	5,140	SSR13672
SS13702	1-8	2 1/2	1 13/16	3 9/16	6 1/8	226.0	9,370	SSR13702

\*Blanks have no rated capacity.

### WARNING

RATED CAPACITY IS DRASTICALLY REDUCED WHEN LOADING AT ANY ANGLE. LOADING MUST NEVER BE MADE AT AN ANGLE GREATER THAN 45° FROM BOLT CENTERLINE. AT AN ANGLE OF 45°, RATED CAPACITY IS REDUCED TO 1/4 OF THE TABULATED VALUE. Reference Page i

# Eye Bolts

## Machinery Style Shoulder Pattern

- Forged/ASTM A489
- 1030 Carbon Steel
- Self-Colored\*\*

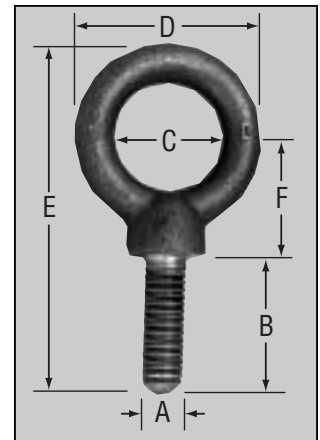

## 8 Thread Pitch Machinery Style Shoulder Pattern

- Forged/ASTM A489
- 1030 Carbon Steel
- Self-Colored\*\*

## High Strength Eye Bolts

- Forged • 8620 Alloy Steel
- Low Temperature Application

## Machinery Style Stainless Steel

- 304 Stainless Steel

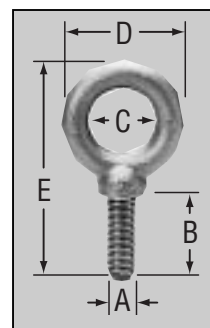

Stock No.	Zinc Plated Stock No.	Thread Size UNC-2A A	Shank Length B	I.D. Eye C	O.D. Eye D	Overall Length E	Center of Eye to Shoulder F	Width of Shoulder G	Approx. Wt. Per 100 Pcs.	Rated Capacity	Blanks*
14611	14611ZP	1/4-20	1	3/4	1 1/16	2 3/8	3/4	1 7/32	5.0	500	R14611
14621	14621ZP	5/16-18	1 1/8	7/8	1 1/16	2 13/16	1 5/16	1 19/32	10.0	900	R14621
14631	14631ZP	3/8-16	1 1/4	1	1 11/16	3 1/4	1 1/8	2 1/32	20.0	1,300	R14631
14638	14638ZP	7/16-14	1 3/8	1 1/32	1 13/16	3 3/16	1 1/4	2 5/32	25.0	1,800	R14638
14641	14641ZP	1/2-13	1 1/2	1 1/16	2 1/8	3 31/32	1 3/8	2 9/32	40.0	2,400	R14641
14650	14650ZP	9/16-12	1 3/4	1 3/8	2 9/16	4 3/4	1 21/32	1 1/32	70.0	3,200	R14650
14661	14661ZP	5/8-11	1 3/4	1 3/8	2 9/16	4 3/4	1 21/32	1 1/32	75.0	4,000	R14661
14672	14672ZP	3/4-10	2	1 1/2	2 13/16	5 1/4	1 13/16	1 3/16	100.0	5,000	R14672
14682	14682ZP	7/8-9	2 1/4	1 11/16	3 3/16	6	2 1/8	1 3/8	160.0	7,000	R14682
14702	14702ZP	1-8	2 1/2	1 13/16	3 3/16	6 5/8	2 5/16	1 9/16	275.0	9,000	R14702
14712	14712ZP	1-1/8-7	2 3/4	2	4 1/16	7 17/32	2 11/16	1 3/4	340.0	12,000	R14712
14723	14723ZP	1-1/4-7	3	2 3/16	4 7/16	8 7/32	2 15/16	1 15/16	465.0	15,000	R14723
14753	14753ZP	1-1/2-6	3 1/2	2 1/2	5 3/16	9 15/32	3 5/16	2 3/16	765.0	21,000	R14753
14770	14770ZP	1-3/4-5	3 3/4	2 7/8	6	10 13/16	4	2 1/2	1145.0	28,000	R14770
14780	14780ZP	2-4 1/2	4	3 1/4	6 7/8	11 7/8	4 3/8	2 7/8	1700.0	38,000	R14780

Part #14650 dimensions not in accordance with ANSI B18.15.  
Shoulder style lifting eye meets MS51937 specification.

Stock No.	Thread Size UNC-2A A	Shank Length B	I.D. Eye C	O.D. Eye D	Overall Length E	Center of Eye to Shoulder F	Width of Shoulder G	Approx. Wt. Per 100 Pcs.	Rated Capacity
814712	1-1/8-8	2 3/4	2	4 1/16	7 17/32	2 11/16	1 3/4	340.0	12,000
814723	1-1/4-8	3	2 3/16	4 7/16	8 7/32	2 15/16	1 15/16	465.0	15,000
814753	1-1/2-8	3 1/2	2 1/2	5 3/16	9 15/32	3 5/16	2 3/16	765.0	21,000
814770	1-3/4-8	3 3/4	2 7/8	6	10 13/16	4	2 1/2	1145.0	28,000
814780	2-8	4	3 1/4	6 7/8	11 7/8	4 3/8	2 7/8	1700.0	38,000

Shoulder style lifting eye meets MS51937 specification.

### Shoulder Pattern

14631LT	3/8	1 1/4	1	1 11/16	3 1/4	1 1/8	-	16.0	1,480
14641LT	1/2	1 1/2	1 1/16	2 1/8	3 31/32	1 3/8	-	34.8	2,700
14661LT	5/8	1 3/4	1 3/8	2 1/2	4 3/4	1 21/32	-	67.0	4,300
14672LT	3/4	2	1 1/2	2 13/16	5 1/4	1 13/16	-	100.0	6,400
14682LT	7/8	2 1/4	1 11/16	3 3/16	6	2 1/8	-	163.0	8,800
14702LT	1 2 1/2	1 3/16	3 9/16	6 5/8	2 5/16	222.0	-	11,600	
14723LT	1-1/4	3	2 3/16	4 7/16	8 7/32	2 15/16	-	444.0	18,400
14753LT	1-1/2	3 1/2	2 1/2	5 3/16	9 15/32	3 5/16	-	736.0	26,600
14780LT***	2 4	3 1/4	6 7/8	11 7/8	4 3/8	-	1670.0	47,600	

\*\*\*These products will be discontinued when stock is depleted.

Stock No.	Thread Size UNC-2A A	Shank Length B	I.D. Eye C	O.D. Eye D	Overall Length E	Approx. Wt. Per 100 Pcs.	Rated Capacity	Blanks*
SS14611	1/4-20	1	3/4	1 1/16	2 3/8	5.0	460	SSR14611
SS14621	5/16-18	1 1/8	7/8	1 1/16	2 13/16	9.6	780	SSR14621
SS14631	3/8-16	1 1/4	1	1 11/16	3 1/4	16.0	1,160	SSR14631
SS14641	1/2-13	1 1/2	1 1/16	2 1/8	3 31/32	34.8	2,150	SSR14641
SS14661	5/8-11	1 3/4	1 3/8	2 9/16	4 3/4	67.0	3,440	SSR14661
SS14672	3/4-10	2	1 1/2	2 13/16	5 1/4	100.0	5,140	SSR14672
SS14702	1-8	2 1/2	1 3/4	3 3/16	6 1/8	260.0	9,370	SSR14702

\*Blanks have no rated capacity.

Shoulder Pattern

### WARNING

RATED CAPACITY IS DRASTICALLY REDUCED WHEN LOADING AT ANY ANGLE. LOADING MUST NEVER BE MADE AT AN ANGLE GREATER THAN 45° FROM BOLT CENTERLINE. AT AN ANGLE OF 45°, RATED CAPACITY IS REDUCED TO 1/4 OF THE TABULATED VALUE. Reference Page i

To Place an Order or for More Information Please Call  
**1-800-338-2658** or visit our website at [www.ewdaniel.com](http://www.ewdaniel.com)

# Eye Bolts & Nut Eye Bolts

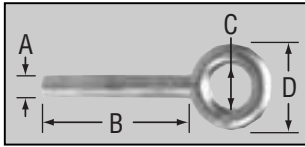

**Plain Pattern  
Stainless Steel**  
• 316 Stainless Steel

## Blanks

Stock No.	Shank Dia. A	Shank Length B	I.D. of Eye C	O.D. of Eye D	Approx. Wt. Per 100 Pcs.
SSR31602	3/8	6	3/4	1 1/2	30
SSR31600	3/8	10	3/4	1 1/2	40
SSR31606	1/2	6	1	1 15/16	42
SSR31605	1/2	12	1	1 15/16	75
SSR31612	5/8	6	1 3/8	2 1/2	98
SSR31610	5/8	12	1 3/8	2 1/2	153
SSR31614	3/4	6	1 1/2	2 13/16	138
SSR31615	3/4	12	1 1/2	2 13/16	216
SSR31617	7/8	12	1 11/16	3 1/4	302
SSR31621	1	6	1 13/16	3 9/16	280
SSR31620	1	12	1 13/16	3 9/16	430

Blanks have no rated capacity.

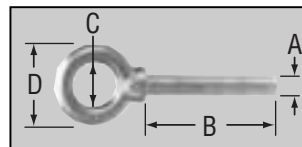

**Shoulder Pattern  
Stainless Steel**  
• 316 Stainless Steel

## Blanks

Stock No.	Shank Dia. A	Shank Length B	I.D. of Eye C	O.D. of Eye D	Approx. Wt. Per 100 Pcs.
SSR31636	3/8	6	3/4	1 1/2	30
SSR31640	3/8	10	3/4	1 1/2	40
SSR31642	1/2	6	1	1 15/16	42
SSR31645	1/2	12	1	1 15/16	75
SSR31648	5/8	6	1 3/8	2 1/2	98
SSR31650	5/8	12	1 3/8	2 1/2	153
SSR31653	3/4	6	1 1/2	2 13/16	138
SSR31655	3/4	12	1 1/2	2 13/16	216
SSR31657	1	6	1 13/16	3 9/16	280
SSR31660	1	12	1 13/16	3 9/16	430

Blanks have no rated capacity.

## Stainless Steel Nut Eye Bolts

- Forged
- 304 Stainless Steel
- Plain Pattern

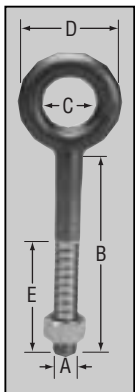

Stock No.	UNC Thread Dia. A	Shank Length B	I.D. of Eye C	O.D. of Eye D	Thread Length E	Approx. Wt. Per 100 Pcs.	Rated Capacity*	Blanks*
SS12314	1/4	4	1/2	1	1	8.0	460	
—	1/4	6	1/2	1	—	9.0	—	SSR12316
SS12323	5/16	4	5/8	1 1/4	1 1/4	15.0	780	
—	3/8	6	3/4	1 1/2	—	29.0	—	SSR12336
SS12341	1/2	4 1/2	1	1 15/16	2	41.0	2,150	
SS12343	1/2	6	1	1 15/16	—	42.0	2,150	SSR12343
—	1/2	12	1	1 15/16	—	55.0	—	SSR12348
SS12350	5/8	4	1 3/8	2 1/2	2 1/4	82.0	3,440	
SS12352	5/8	6	1 3/8	2 1/2	2 1/4	98.0	3,440	SSR12352
—	5/8	12	1 3/8	2 1/2	—	125.0	—	SSR12357
SS12362	3/4	6	1 1/2	2 13/16	2 1/2	138.0	5,140	SSR12362
—	3/4	12	1 1/2	2 13/16	—	175.0	—	SSR12367
SS12371	7/8	6	1 11/16	3 1/4	2 1/2	214.0	7,130	SSR12371
—	7/8	12	1 11/16	3 1/4	—	300.0	—	SSR12375
SS12380	1	6	1 13/16	3 9/16	3	280.0	9,370	SSR12380
—	1	12	1 13/16	3 9/16	—	350.0	—	SSR12385

\*Rated capacity — Full sized shank and eye — unaltered.

\*Blanks have no rated capacity. All stainless electropolished.

## Stainless Steel Nut Eye Bolts

- Forged
- 304 Stainless Steel
- Shoulder Pattern

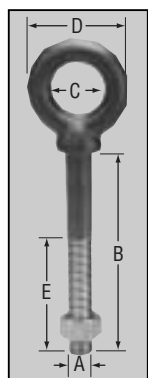

Stock No.	Thread Dia. A	Shank Length B	I.D. of Eye C	O.D. of Eye D	Thread Length E	Approx. Wt. Per 100 Pcs.	Rated Capacity*	Blanks*
SS17734	3/8-16	4 1/2	3/4	1 1/2	1 1/2	25.0	1,160	SSR17334
—	3/8-16	6	3/4	1 1/2	—	29.0	—	SSR17736
—	3/8-16	10	3/4	1 1/2	—	34.0	—	SSR17739
SS17743	1/2-13	6	1	1 15/16	2	42.0	2,150	SSR17743
—	1/2-13	12	1	1 15/16	—	55.0	—	SSR17745
SS17752	5/8-11	6	1 3/8	2 1/2	2 1/4	98.0	3,440	SSR17752
—	5/8-11	12	1 3/8	2 1/2	—	125.0	—	SSR17754
SS17762	3/4-10	6	1 1/2	2 13/16	2 1/2	138.0	5,140	SSR17762
—	3/4-10	12	1 1/2	2 13/16	—	175.0	—	SSR17767
SS17690	1-8	6	1 13/16	3 9/16	3	280.0	9,370	SSR17690
—	1-8	12	1 13/16	3 9/16	—	350.0	—	SSR17693

\*Rated capacity — Full sized shank and eye — unaltered.

\*Blanks have no rated capacity.

All stainless electropolished.

### WARNING

RATED CAPACITY IS DRASTICALLY REDUCED WHEN LOADING AT ANY ANGLE. LOADING MUST NEVER BE MADE AT AN ANGLE GREATER THAN 45° FROM BOLT CENTERLINE. AT AN ANGLE OF 45°, RATED CAPACITY IS REDUCED TO 1/4 OF THE TABULATED VALUE. Reference Page i

# Eye Bolts

## Nut Eye Bolts

- Forged
- 1030 Carbon Steel
- Hot Galvanized\*\*
- Plain Pattern

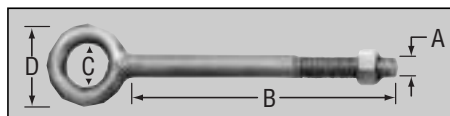

### NUT EYE BOLT SPECIFICATIONS

Length of thread approximately four times the diameter of shank. Shanks 10 inches or longer are threaded 4 inches. Intermediate and longer sizes also available.

1/4" size only, electro-galvanized after threading. All other sizes hot galvanized. Available mechanical galvanized upon request.

All standard stock eye bolts have UNC-2A threads and are supplied with American Standard Galvanized Oversized Hex Nuts (unassembled).

### WARNING

RATED CAPACITY IS DRASTICALLY REDUCED WHEN LOADING AT ANY ANGLE. LOADING MUST NEVER BE MADE AT AN ANGLE GREATER THAN 45° FROM BOLT CENTERLINE. AT AN ANGLE OF 45°, RATED CAPACITY IS REDUCED TO 1/4 OF THE TABULATED VALUE. *Reference Page i*

RATED CAPACITY REFERS TO EYE BOLT ONLY. IMPROPER TORQUING, INFERIOR QUALITY NUTS AND OTHER FACTORS CAN SUBSTANTIALLY REDUCE RATED CAPACITY.

Stock No.	Thread Dia. A	Shank Length B	I.D. Eye C	O.D. Eye D	Approx. Wt. Per 100 Pcs.	Rated Capacity	Blanks*
12310	1/4-20	2	1/2	1	6.0	500	
12312	1/4-20	3	1/2	1	7.0	500	
12314	1/4-20	4	1/2	1	8.0	500	
12315***	1/4-20	5	1/2	1	11.0	500	
12316	1/4-20	6	1/2	1	13.0	500	R12316
12319	5/16-18	2 1/4	5/8	1 1/4	11.0	800	
12321	5/16-18	3	5/8	1 1/4	13.0	800	
12323	5/16-18	4	5/8	1 1/4	15.0	800	
12325	5/16-18	5	5/8	1 1/4	17.0	800	
12326	5/16-18	6	5/8	1 1/4	20.0	800	R12326
12330	3/8-16	2 1/2	3/4	1 1/2	17.0	1,200	
12331	3/8-16	3	3/4	1 1/2	21.0	1,200	
12333	3/8-16	4	3/4	1 1/2	24.0	1,200	
12334***	3/8-16	4 1/2	3/4	1 1/2	25.0	1,200	
12335***	3/8-16	5	3/4	1 1/2	27.0	1,200	
12336	3/8-16	6	3/4	1 1/2	30.0	1,200	R12336
12338	3/8-16	8	3/4	1 1/2	36.0	1,200	
12339	3/8-16	10	3/4	1 1/2	40.0	1,200	R12339
12340	1/2-13	3 1/4	1	2	40.0	2,100	
12341	1/2-13	4	1	2	41.0	2,100	
12343	1/2-13	6	1	2	42.0	2,100	R12343
12345	1/2-13	8	1	2	55.0	2,100	
12347	1/2-13	10	1	2	67.0	2,100	
12348	1/2-13	12	1	2	75.0	2,100	R12348
12350	5/8-11	4	1 1/4	2 1/2	82.0	3,200	
12351	5/8-11	5	1 1/4	2 1/2	91.0	3,200	
12352	5/8-11	6	1 1/4	2 1/2	98.0	3,200	R12352
12354	5/8-11	8	1 1/4	2 1/2	120.0	3,200	
12356***	5/8-11	10	1 1/4	2 1/2	134.0	3,200	
12357	5/8-11	12	1 1/4	2 1/2	153.0	3,200	R12357
12358***	5/8-11	15	1 1/4	2 1/2	178.0	3,200	
12360	3/4-10	4	1 1/2	3	118.0	4,500	
12362	3/4-10	6	1 1/2	3	138.0	4,500	R12362
12364	3/4-10	8	1 1/2	3	168.0	4,500	
12366***	3/4-10	10	1 1/2	3	192.0	4,500	
12367	3/4-10	12	1 1/2	3	216.0	4,500	R12367
12368***	3/4-10	15	1 1/2	3	254.0	4,500	
12369***	3/4-10	18	1 1/2	3	304.0	4,500	R12369
12370	7/8-9	5	1 3/4	3 1/2	203.0	7,000	
12371	7/8-9	6	1 3/4	3 1/2	214.0	7,000	R12371
12373	7/8-9	8	1 3/4	3 1/2	235.0	7,000	
12374	7/8-9	10	1 3/4	3 1/2	268.0	7,000	
12375	7/8-9	12	1 3/4	3 1/2	302.0	7,000	R12375
12380	1-8	6	2	4	280.0	8,500	R12380
12382	1-8	8	2	4	335.0	8,500	
12384	1-8	10	2	4	365.0	8,500	
12385	1-8	12	2	4	430.0	8,500	R12385
12386***	1-8	15	2	4	470.0	8,500	
12387	1-8	18	2	4	550.0	8,500	R12387
12390	1-1/4-7	6	2 3/16	4 7/16	500.0	13,500	R12390***
12391***	1-1/4-7	8	2 3/16	4 7/16	580.0	13,500	
12393	1-1/4-7	12	2 3/16	4 7/16	715.0	13,500	R12393
12396	1-1/2-6	12	2 1/2	4 7/16	1080.0	20,000	R12396
12405	2	12	3 1/2	6 7/8	1500.0	35,000	R12396

\*Blanks have no rated capacity.

\*\*Self-colored and other finishes available. Call for quote.

Special bolt/thread lengths available. Call for quote.

\*\*\*These products will be discontinued when stock is depleted.



# Eye Bolts

Stock No.	UNC Thread Dia. A	Shank Length B	I.D. Eye C	O.D. Eye	Min. or Std. Thread Length D	Approx. Wt. Per 100 Pcs.	Rated Capacity	Blanks*
15710	1/4	2	1/2	15/16	1	7.7	400	—
15714	1/4	4	1/2	13/16	1	11.3	400	—
15719	5/16	2 1/4	5/8	1 1/4	1 1/4	13.3	800	—
15724	5/16	4 1/4	5/8	1 1/4	1 1/4	17.1	800	—
15730	3/8	2 1/2	3/4	1 7/16	1 1/2	20.5	1,200	—
15734	3/8	4 1/2	3/4	1 1/2	1 1/2	25.6	1,200	—
15738***	3/8	6	3/4	1 1/2	1 1/2	30.0	—	R15738
15740	1/2	3 1/4	1	1 15/16	2	43.8	2,100	—
15741	1/2	4	1	1 15/16	2	48.6	2,100	—
15743	1/2	6	1	1 15/16	2	59.0	2,100	R15743
—	1/2	12	1	1 15/16	2	75.0	—	R15747
—	1/2	18	1	1 15/16	2	110.0	—	R15748
15750	5/8	4	1 1/8	2 1/2	2 1/2	92.0	3,200	—
15752	5/8	6	1 1/8	2 1/2	2 1/2	110.0	3,200	R15752
—	5/8	12	1 1/8	2 1/2	2 1/2	135.0	—	R15754
15760	3/4	4 1/2	1 1/2	3	3	135.0	4,500	—
15762	3/4	6	1 1/2	3	3	153.0	4,500	R15762
—	3/4	12	1 1/2	3	3	216.0	—	R15766
—	3/4	18	1 1/2	3	3	304.0	—	R15769

Thread length equals four times the diameter.  
1/4" size only. Electro-Galvanized after threading.

\*Blanks have no rated capacity.

\*\*\*These products will be discontinued when stock is depleted.

## Nut Eye Bolts

- Forged • Shoulder Pattern
- Hot Galvanized
- 1030 Carbon Steel★

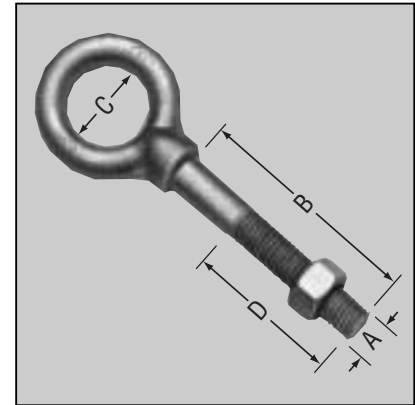

Not recommended for lifting.

Stock No.	Thread Dia. A	Shank Length B	I.D. Eye C	O.D. Eye D	Min. or Std. Thread Length E	Approx. Wt. Per 100 Pcs.	Rated Capacity	Blanks*
17611***	1/4-20	1	1/2	15/16	7/8	4.8	400	—
17621***	5/16-18	1 1/8	5/8	1 1/16	1	9.6	800	—
17629***	3/8-16	1/2	1	1 11/16	3/8	14.1	1,200	—
17630	3/8-16	3/4	1	1 11/16	5/8	15.6	1,200	—
17631***	3/8-16	1 1/4	3/4	1 7/16	1 1/8	14.2	1,200	—
17632	3/8-16	2	3/4	1 7/16	1 7/8	16.3	1,200	—
17633	3/8-16	3 1/2	1	1 21/32	3 3/8	22.7	1,200	—
17640***	1/2-13	1	9/16	1 5/16	7/8	16.9	2,100	—
17641***	1/2-13	1 1/2	1	1 15/16	1 3/8	35.3	2,100	—
17744	1/2-13	1	1 3/16	1 15/16	1	17.5	2,100	—
17642	1/2-13	2 3/16	1 3/16	2 1/16	2 1/16	41.0	2,100	—
17662	5/8-11	2 5/8	1 3/8	2 1/2	2 1/2	78.0	3,200	—
17673	3/4-10	3 1/2	1 1/2	2 13/16	3 3/8	124.0	4,500	—
17685***	1-8	3 1/4	1 13/16	3 3/16	3 1/8	295.0	8,500	—
17690	1-8	6	1 13/16	3 3/16	5 3/4	400.0	8,500	R17690
17693	1-8	12	1 13/16	4 7/16	11 1/2	550.0	8,500	R17693
—	1-8	18	1 13/16	4 7/16	—	780.0	—	R17695
17696	1 1/4-7	6	2 3/16	4 7/16	5 3/4	580.0	13,500	R17696
17699	1 1/4-7	12	2 3/16	4 7/16	11 1/2	760.0	13,500	R17699

\*Blanks have no rated capacity.

\*\*Additional platings available. Call for quote.

\*\*\*These products will be discontinued when stock is depleted.

## Special Sizes

- Forged
- Shoulder Pattern
- Self-Colored\*\*
- 1030 Carbon Steel

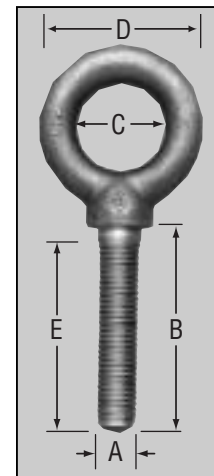

# DIN 580/582 Eye Bolts & Nuts & Pad "D" Eyes

## Metric Eye Bolts

Manufactured to European Standards

- DIN 580
- 1015 Carbon Steel
- Self-Colored
- Forged

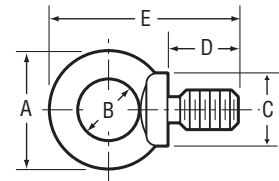

Stock No.	Size	O.D. Eye A	I.D. Eye B	Width of Shoulder C	Shank Length D	Overall Length E	Approx. Wt. Per C in Lbs.	Rated Capacity in Kgs.
58006	6MM	27	15	15	13	27	4.9	70
58008	8MM	36	20	20	13	36	13.2	140
58010	10MM	45	25	25	17	45	24.2	230
58012	12MM	54	30	30	20.5	53	39.6	340
58014	14MM	63	35	35	27	62	55	490
58016	16MM	63	35	35	27	62	61.6	700
58020	20MM	72	40	40	30	71	100	1200
58024	24MM	90	50	50	36	90	162.8	1800
58030	30MM	108	60	65	45	109	365.2	3600
58036	36MM	126	70	75	54	128	583	5100
58042	42MM	144	80	85	63	147	886.6	7000

All dimensions are in millimeters.

\*Zinc Plating Special Order

NOTE: These products are manufactured to Edward W. Daniel Co. quality standards via global contracts.

## Metric Eye Nuts

Manufactured to European Standards

- DIN 582
- 1015 Carbon Steel
- Self-Colored
- Forged

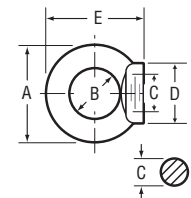

Stock No.	Size	O.D. Eye A	I.D. Eye B	Thread Dia. C	Width of Shoulder D	Overall Length E	Approx. Wt. Per C in Kgs.
58208	8MM	36	20	8-1.25	20	36	10.6
58210	10MM	45	25	10-1.5	25	45	19.4
58212	12MM	54	30	12-1.75	30	53	31.7
58214	14MM	54	36	14-2	36	52	38
58216	16MM	63	35	16-2	35	62	49.3
58220	20MM	72	40	20-2.5	40	71	80
58224	24MM	90	50	24-3	50	90	130.3
58230***	30MM	108	60	30-3.5	65	109	292.2

All dimensions are in millimeters.

Rated capacities are same as above when properly installed. (See DIN 580)

\*Zinc Plating Special Order

NOTE: These products are manufactured to Edward W. Daniel Co. quality standards via global contracts.

\*\*\*These products will be discontinued when stock is depleted.

## Pad "D" Eyes

- Forged Carbon Steel
- Self-Colored

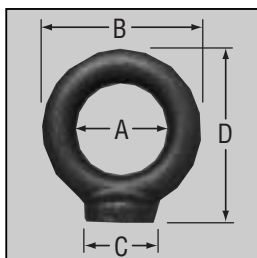

Stock No.	I.D. Eye A	O.D. Eye B	Width of Shoulder C	Overall Length D	Approx. Wt. Per 100 Pcs.
41500	3/4	1 1/16	17/32	1 3/8	7.5
41502	7/8	1 7/16	19/32	1 11/16	9.4
41503	1	1 1 1/16	21/32	2	11.0
41504	1 1/16	2 1/8	29/32	2 7/16	16.0
41506	1 3/8	2 9/16	1 1/32	3	56.0
41507	1 1/2	2 13/16	1 3/16	3 1/4	86.0

Not recommended for Lifting.